

ASAHI KASEI ULTRAFILTRATION MEMBRANE MODULE

Microza™ OLT-6036HA

OPERATING INSTRUCTIONS



Caution

- To ensure safe and proper use of the UF modules, carefully read and adhere to all of the safety instructions in these Operating Instructions.
- Maintain this manual in a convenient location for consultation.

12401J

PREFACE

The UF module and the module system may be subject to the Export Control Regulation of Japan. If it is the case, the Export license is required as the formal application for the export.

Asahi Kasei Chemicals Corporation (hereinafter "Asahi Kasei") inspects every Microza UF module, and ships only the modules that meet Asahi Kasei's specifications. However, even though adhering to operating parameter as outlined in this manual, there remains possibility of membrane failure resulting in a breach, or leakage, between the feed and permeate sides of the membrane. It is therefore strongly recommended that the user of Microza provide adequate detection equipment and embody quality control protocols and procedures to avoid damage caused by membrane failures. Please ensure that appropriate procedures are enacted to avoid contact with chemicals and leaking fluids resulting from module housing failure. Asahi Kasei shall not be held liable for consequential damages or losses caused by such noted membrane failure or for non-adherence of the above noted recommendations.

Asahi Kasei shall provide replacement module free of charge if you find any defects against its shipment standards and notify thereof in writing within six (6) month after the delivery date, under Section 526 of Japanese Commercial Code.

CONTENTS

	Page
1 . SAFETY INSTRUCTIONS-----	3
2 . APPLICATION OF MODULE -----	7
3 . MODULE PRECAUTIONS -----	8
4 . SPECIFICATIONS-----	16
5 . SHIPPING INSPECTIONS -----	18
6 . FUNDAMENTAL CHARACTERISTICS-----	19
7 . HOW TO FIX MODULE & PIPING -----	24
8 . STANDARD OPERATING PARAMETERS-----	29
9 . INSTRUCTIONS FOR MODULE USE -----	31
1 0 . DRAWINGS OF MODULE AND PARTS -----	38

1. SAFETY INSTRUCTIONS

Adhere to the Notes in these instructions when using the OLT-6036HA ultrafiltration module (hereinafter “UF module”) to ensure correct and safe operation. Asahi Kasei shall not be held liable for injuries, losses, or consequential damages caused by non-adherence to these instructions.

1-1. Safety Symbol

The Safety Notes in these instructions and the warning labels attached to the module are classified as follows:

	Warning
Incorrect handling or operation of the UF module by not adhering to the 'warning' may cause serious, and possibly, fatal injury.	

	Caution
Incorrect handling or operation of the UF module by not adhering to the 'caution' may cause injury to personnel and/or damage and loss of equipment.	

1-2. Safety Symbol Legend

There are three types of signals in these instructions:



WARNING or CAUTION.



NO or DO NOT.



NOTICE.

1-3. Safety Guidelines



Warning



Wear protectors when cutting the module for disposal as flying fragments may cause injury.



When handling hazardous chemicals, always wear protectors such as safety goggles and rubber gloves. If the solution comes in contact with eyes or skin, immediately rinse thoroughly with water. Then seek professional medical attention as soon as possible as there may be serious injury to eyes and skin.



Do not use the module for liquids containing organic solvents as it may cause cracks in the module housing. Steam or hot water may blast out from such cracks during sterilization by steam or during high-temperature operation, which may result in burns. (Refer to Sections 3-1 and 3-2.)



Temperature of module and pipe is elevated when the UF system is disinfected with hot water. Hot water may leak or spout out from modules and pipes. Following care should be taken to prevent burns and injuries.

1. Cover all modules and parts in the UF unit to protect workers from possible splashing hot water. Insulate thermally all pipes and parts of the unit to which workers may contact by chance.
2. Check all seal parts of pipeline prior to hot water operation.



Avoid shocks of temperature and/or pressure or repeated up-and-down of them, even if they are within allowed service conditions in the specification.



Caution



Module contains preservative solution, formaldehyde 0.37%. Ventilate the environment for draining out and wear protectors to prevent the solution from touching eyes and hands.



Do not allow the module to come in contact with organic solvents, or solvent vapors, including cleaning agents which contain organic solvents, or with paints, or labels or tapes with adhesive backings. Contact with organic solvents may cause cracking of plastic housings.



The weight of a module is about 35kg, when filled with water fully. Due to the high weight of modules, they should be handled by two or more workers.



Operate UF module within allowed specification. The operation may damage the module. (Refer to Section 4.)



Ensure that adequate measures are in place to avoid damage to peripheral units and/or environmental contamination from exposure to leaking or splashing liquid.

2. APPLICATION OF MODULE

Use OLT-6036HA as a final filter for ultrapure water in fields such as the semiconductor industry. Do not use them for other applications. The amount of Ca that elutes from OLT-6036HA is expected to be smaller than OLT-6036H.

Consult Asahi Kasei:

- If an application is not specifically noted in these Instructions.
- If there is a change in the application or in the system operation after the modules (or system) are deployed.

Asahi Kasei shall not be held liable for consequential damages or losses caused by such noted membrane failure or for non-adherence of the above noted recommendations.

These instructions include some typical applications and operating parameters. Should the application differ due to variant feeds and/or operating parameters, please first ensure the suitability of the module prior to use.

3. MODULE PRECAUTIONS

Carefully adhere to the Operating Instructions for proper and safe use of the module.

3-1. Notes on Solvents and Medical Agents

Alarming Label

To draw attention to solvents, Asahi Kasei affixes the following warning label to polysulfone resin module housings.



3-2. Chemical Resistance of Module Housing

Note:

Don't come to contact with following solvents and/or chemicals or vapors of them to prevent stress cracking of module housing:

Classification	Typical Examples
Fatty series organic halogen carbon hydride	Methylene chloride, trichloroethylene, Chloroform, Tetrachloroethylene
Aromatic series organic halogen carbon hydride	Chlorobenzyl,
Fatty series amine, Amides	Dimethylformamide (DMF), Dimethylacetamide (DMAC)
Cyclic amine, Aromatic series amine	N methyl-2-Pyrrolidone (NMP), Pyridine
Nitriles	Acetonitrile
Cyclic ketone	Cyclohexanone
Thinners	Thinners
Esters	Ethyl acetate, Butyl acetate
Ethers	Isopropyl ether, Ethyl ether
Ketones	Acetone, Methyl ethyl ketone (MEK)
Aromatic series carbon hydride	Benzol, Toluene, Xylene
Alcohols	Methanol, Ethanol
Fatty series carbon hydride	Hexane, Heptane, DOP, Kerosene, Gasoline, Edible oil
Strong acids, Strong bases	Concentrated nitric acid, Concentrated sulfuric acid, Chromic acid, Concentrated ammonia, Ethyl amine

Other Notices

- ◆ Do not contact module with rubber sheet that contains ester plasticizer or with soft PVC hose. Trace plasticizer or solvent may cause crack on module housing
- ◆ Do not wipe off module with solvent wet cloth, or paste PVC tape or gum tape. Do not mark on the module housing with a felt pen.
- ◆ Wash module with water and wipe it with dry cloth to remove dust/stain on the module.



Examples of Past Accidents

- ◆ Paint stuck to a module and the section with the paint cracked.
- ◆ An adhesive used to fix a heat insulator to a module caused module cracks.
- ◆ Soft PVC sheet to fix module with U-bolts, as a cushion, caused module crack (migration of plasticizer).

3-3. Preservative Solution.

The module is filled with 0.37% formaldehyde solution (preservative solution) to prevent proliferation of bacteria and to keep UF membrane wet. Thoroughly wash off the preservative with ultrapure water before using the module. Refer to the following notices for use.

- Some modules shipped overseas are filled with an aqueous preservative solution of 65% glycerine and 2% ethanol. This solution prevents membrane freezing and microorganism growth. Consult Asahi Kasei for handling these modules.

 Caution	
	Formaldehyde solution (0.37%) is used as a preservative solution. This preservative solution may cause an inflammation when entering eyes. Always wear protectors, such as safety goggles and rubber gloves, to prevent skin contact and eye contact.

3-4. General

System Cleaning before Operation

Thoroughly clean inside the piping before operation. Foreign matter, such as metal shards in the tank or in pipe lines, may seriously damage the membranes. Oil spill and detergent also become causes of membrane fouling.

Locating the System

Protect the modules from direct sunlight and ultraviolet light as they may degrade the UF membrane and module housing.

Module Mounting

Follow the label instruction on the module, "Feed Inlet" and "Concentrate Outlet", for mounting on the module rack.

Module Mounting

The weight of a module is about 35kg, when filled with water fully. Module support only by pipes on the rack may damage module and/or pipes (refer to Paragraph 7-1 for a counter measure). Module fixing with a U-bolt or a U-band may cause case damage. Refer to the next paragraphs "Thermal Expansion of Module" and "Module Fixing Method and Piping" shown below in this manual.

Thermal Expansion of Module

Module extends its length by about 4 mm, when its temperature changes from 20 °C to 90 °C (linear expansion coefficient: $5.5 \times 10^{-5}/^{\circ}\text{C}$). Think over counter measures for the expansion in the design of module rack and piping. Firm supporting of module to pipe or rack and firm fixing of it with U-bands, etc. may cause module break by concentration of expansion stress to it.

Module Fixing Method and Piping

- ◆ Use two (2) filtrate nozzles to draw out filtrate from module. Filtrate pipe should be designed, so as there remains no air bubble in it. It is recommended to place a filtrate header at a position higher than modules.
- ◆ The module should be placed in an upright position on the rack with the feed side at the bottom and concentrate side at the top. At least feed nozzle and concentrate nozzle of the module should be at upright position when the module is placed horizontally by an unavoidable reason. Follow to the label indication of feed side and concentrate side nozzles of the module.
- ◆ Pay attention for avoiding unnecessary stress on the module in course of designing of module rack and piping. No thermal stress should be given, for example, in the course of hot water disinfection by expansion absorption mechanisms. Use dummy modules (sold separately on request) to assemble a module rack.
- ◆ Note that the diameter of the dummy module (165mm ϕ) is different from that of the actual module (172mm ϕ).
- ◆ The pressure resistance of dummy module is max. 200 kPa. If dummy modules are used for cleaning, make sure that this pressure is not exceeded.

3-5. Notices on UF Unit Operation

Prohibition of abrupt startup and sharp fluctuation of pressure

If a large amount of water is fed into the module and the system is started sharply while air is remaining in the module or the piping, the module housing or membrane may be damaged by water hammer phenomenon. Operate with filtrate flow rate $2\text{m}^3/\text{hr}$ at first and increase it up to the desired level after the air in the modules has been vent out. Don't give thermal or pressure shock or repeated up-and-down to the Unit even if they are within available limits.

Prohibition of Flushing

Flushing is not effective to remove accumulated foreign matter on the feed side of the membrane, in the case of "Outside to Inside Filtration mode" type module.

Prohibition of Dead-End Operation

No DEAD-END operation allowed. DEAD-END operation may damage UF membrane and module case.

Dead-end Filtration

Dead-end filtration (100% recovery of feed water as product) may cause quick fouling of UF membrane by particulates and/or bacteria and the membrane may lose filtration ability. If operation is performed in dead-end mode or in a mode close to this mode, refer to Section 9-4 "Recovery Rate" .

Prohibition of Thermal Shock



Adhere to instructions in this manual in the case of hot water disinfection. Thermal shock, too quick rising up or falling down of feed water temperature, may damage UF membrane and module case. Refer to the figures shown below.

- ◆ Rising speed: $< 5^\circ\text{C} / \text{min}$.
- ◆ Falling down speed: $< 5^\circ\text{C} / \text{min}$.

Hot DI Water Operation

Temperature of module and pipe is elevated when the UF system is disinfected with hot water. Hot water may leak or spout out from modules and pipes. Following care should be taken to prevent burns and injuries:

- ◆ Check leak from seals prior to Hot DI water operation.
- ◆ Cover all modules and parts in the UF unit to protect workers from possible splashing hot water. Insulate thermally all pipes and parts of the unit to which workers may contact by chance.
- ◆ Avoid shocking the UF unit thermally and hydraulically, especially during Hot DI water operation.

	
	Warning
There are possibilities of scalding by hot water. Cover all dangerous parts and/or wear protectors.	

3-6. STORAGE & TRANSPORTATION

Temporary Suspension of Processing and Module Storage

Fill ultrapure water and seal the module, when the suspension term is shorter than three (3) days. Longer suspension may induce proliferation of bacteria, increase of particle count and need a longer rising up time of specific resistance. Storage without water in the module may dry UF membrane and the membrane loses its performance as UF membrane.

Long-Term Suspension and Module Storage

Fill 0.37% formaldehyde solution for suspension/storage longer than three (3) days. Keep modules in a cool and dry place, away from direct sunlight. Rinse modules thoroughly, till no formaldehyde is detected for reuse. Consult Asahi Kasei for storage periods exceeding one (1) year.

Protect from Freezing

Ensure that the membrane is not allowed to freeze. Freezing can damage the modules and lose the performance of UF membrane.

Keep Wet

When suspending operation or storing the modules, ensure that the modules are filled with clean water to prevent membrane drying, which may result in the loss of UF membrane properties and productivity (capacity). Don't leave modules without water especially when they are going to be mounted or dismounted from the module rack. Drain out water that is used for Hot DI water operation, after it comes to normal temperature. Contact with air, while the temperature of UF membrane is still high, dries the membrane very quickly and damages it.

Avoid UV Light and High Temperature Exposure

Do not expose modules to direct sunlight, other UV light sources, or high temperatures for extended periods as the module housing and UF membrane may be degraded.

Avoid Mechanical Impact

Modules must not be subjected to sudden impact, mechanical shock, or vibration as it may result in damaged membranes, even if there is no damage on the housing.

Avoid Transporting the System with Modules Installed

Remove the modules from the UF system for transportation. Transportation induced vibration, mechanical shock, or impact may damage the membranes. Use of dummy modules is recommended for transportation.

3-7. Other Notices

Protection of Module Filtrate Side from Contaminations

The filtrate side of the module is free from particles when the module is shipped from Asahi Kasei. Be careful not to spoil the clean part.

Notice on Use of Hydrogen Peroxide



UF membrane is easily damaged by hydrogen peroxide. Use only dilute and room temperature hydrogen peroxide.

Notice on Selection of Piping Materials

Select those materials with lowest extractable.

3-8. Module Disposal

Modules are to be disposed of in accordance with applicable local ordinances and adhering to applicable regulatory requirements.

	
Warning	
	Wear protectors when cutting the module for disposal as flying fragments could cause injury.

4. SPECIFICATIONS

Module specifications are given in Table 4-1.

The module is manufactured in a clean environment and is filled with 0.37% formaldehyde solution (preservative solution) after disinfection to prevent proliferation of bacteria and to keep UF membrane wet. Particle-free ultrapure water without viable cells can easily be obtained if the preservative solution is replaced with ultrapure water continuously.

Table 4-1 Module Specifications

Specifications	Hollow fiber membrane size	0.6mm ϕ (ID)
	Effective membrane area	34m ²
	Module diameter	172mm ^{*1}
	Module length	1,177mm
Performance	Nominal molecular weight cutoff	6,000
	Permeate flow rate	16m ³ /hr or more (25°C, 100 kPa) ^{*2}
Operating Parameter ^{*3}	Max. trans-membrane pressure	300kPa (25°C)
	Max. feed water-side pressure	900kPa (25°C)
	Max. permeate-side pressure	900kPa (25°C)
	Max. temperature used	80°C (but up to 90°C during hot water sanitization)
	pH range	1 - 14
Materials	Hollow fiber	Polysulphone series
	Module housing	Polysulphone series
	Potting material	Epoxy resin
	Gasket	F-rubber
Preservative Solution	0.37% formaldehyde solution ^{*4}	

*1: Note that the diameter of a dummy module is 165mm ϕ and that of the actual module is 172mm ϕ .

*2: Note that this figure is not the design flux but the initial filtration rate achieved when pure water is filtrated at 25°C.

*3: Refer to Table 9-6 for the in-depth relationship between water temperatures and filtration fluxes.

*4: Some modules shipped overseas are filled with an aqueous preservative solution of 65% glycerine and 2% ethanol.

- *1: Transmembrane pressure = $P_i - P_{f1}$
Transmembrane pressure is defined as " $P_i - P_{f1}$ "
- *2: Feed water-side pressure = P_i
- *3: Permeate-side pressure = P_{f1}

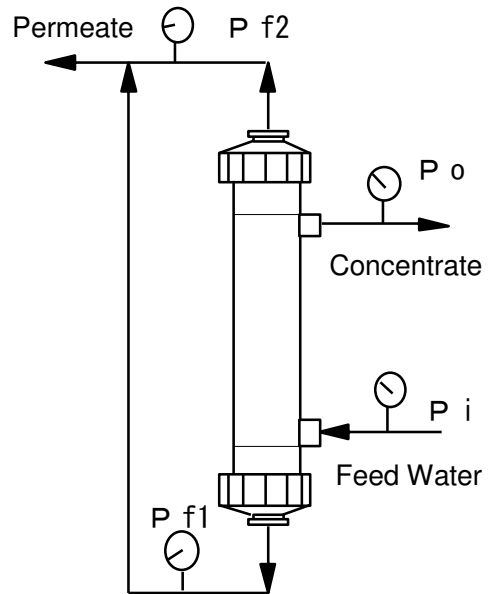

	<h2>Warning</h2>
	Operate UF module within allowed specification. The operation may damage the module.

- ◆ Consult Asahi Kasei if you wish to use the OLT-6036SA for a higher maximum feed pressure desired.
- ◆ Consult Asahi Kasei if you wish to use the OLT-6036VA for a higher pressure desired in a hot ultrapure water line.

5. SHIPPING INSPECTIONS

Asahi Kasei ships all modules after inspections by its own shipping standard.

Inspection items are as follows:

- 1. Cut-off molecular weight**
- 2. Permeate Flux Inspection**
- 3. Dimension Inspection**
- 4. External Appearance Inspection**
- 5. Integrity Testing**
- 6. Module Leak**
- 7. Particle Counts in Filtrate**
- 8. Specific Resistivity of Filtrate**

6. FUNDAMENTAL CHARACTERISTICS

6-1. Average Filtration Pressure and Filtrate Flow Rate

An example of relationship between average filtration pressure and filtrate flow rate is given in Figure 6-1.

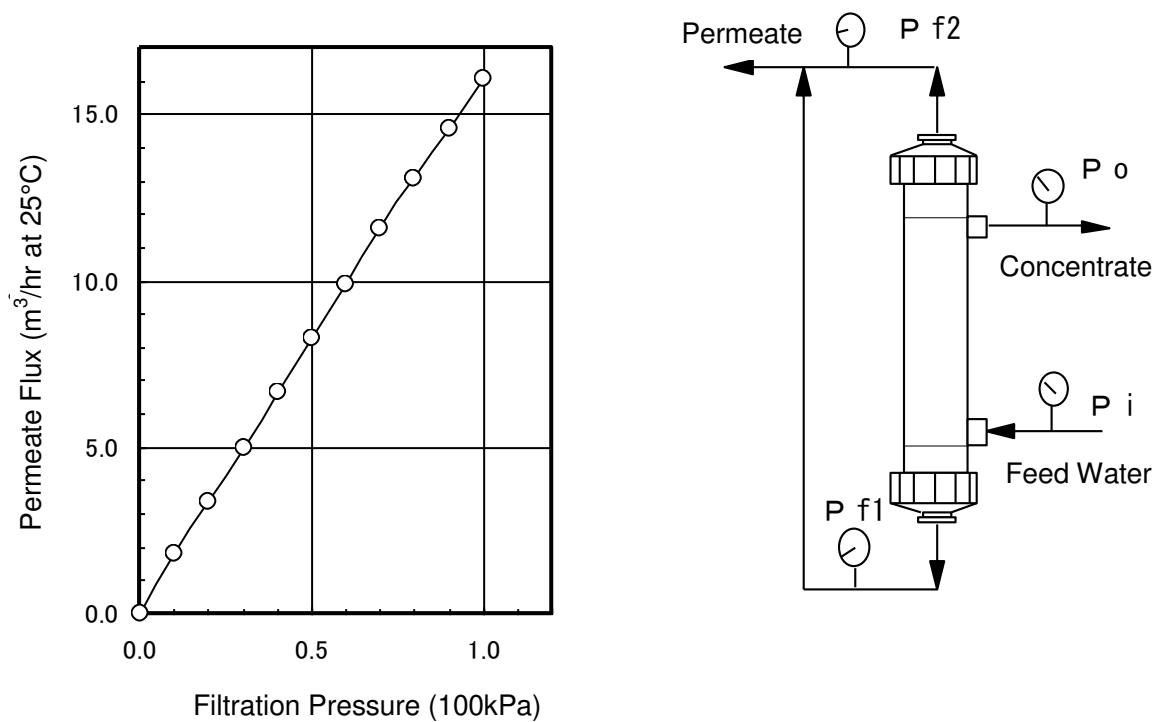

Test Condition

$$\text{Filtration Pressure} = \frac{(P_i + P_o)}{2} - \frac{P_{f1} + P_{f2}}{2}$$

- ◆ Feed water: Ultrapure water; particle count less than 50pcs./ml, larger than 0.1μm
- ◆ Filtrate recovery: 98% of feed water at 25°C

Fig. 6-1 Filtration Pressure and Permeate Flux

6-2. Feed Flow Rate and Pressure Drop

An example of relationship between feed flow rate and pressure drop is shown in Figure 6-2.

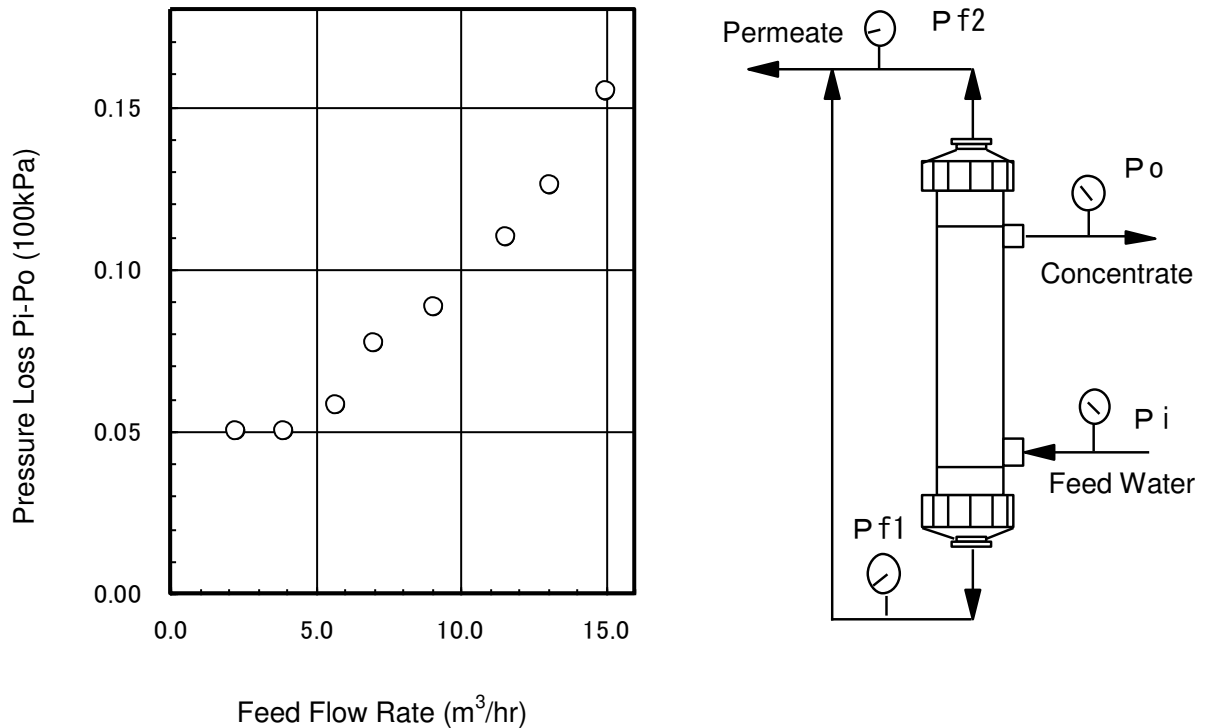

Test Condition

- ◆ Module: As shown above, a module is placed in an upright position and feed water is fed to bottom feed nozzle.
- ◆ Feed water: Ultrapure water; particle count less than 50pcs./ml, larger than 0.1 μ m
- ◆ Pressure drop = (Pi - Po) (100kPa)
- ◆ Filtrate recovery: 98% of feed water at 25°C

Fig. 6-2 Feed Water Volumes and Pressure Losses

6-3. Recoverability of Permeate Nonconductivity after Startup

This module is filled with 0.37% formaldehyde solution and sealed. The following graph shows data regarding a rinse process. This data represents only one example of rinsing in our system, so that permeate nonconductivity does not necessarily recover at all sites in the same way as indicated here.

Some modules shipped overseas are filled with an aqueous preservative solution of 65% glycerine and 2% ethanol. Consult Asahi Kasei for data on rinsing these modules.

Recoverability of Permeate Nonconductivity

Figure 6-3-1 shows an example of changes in the recoverability of permeate nonconductivity. The time required to recover permeate nonconductivity is shortened as the volume of feed water increases. Set the module on the unit and then rinse the module by feeding ultrapure water of 18 megohms-cm (25°C) or more until the predetermined nonconductivity is reached.

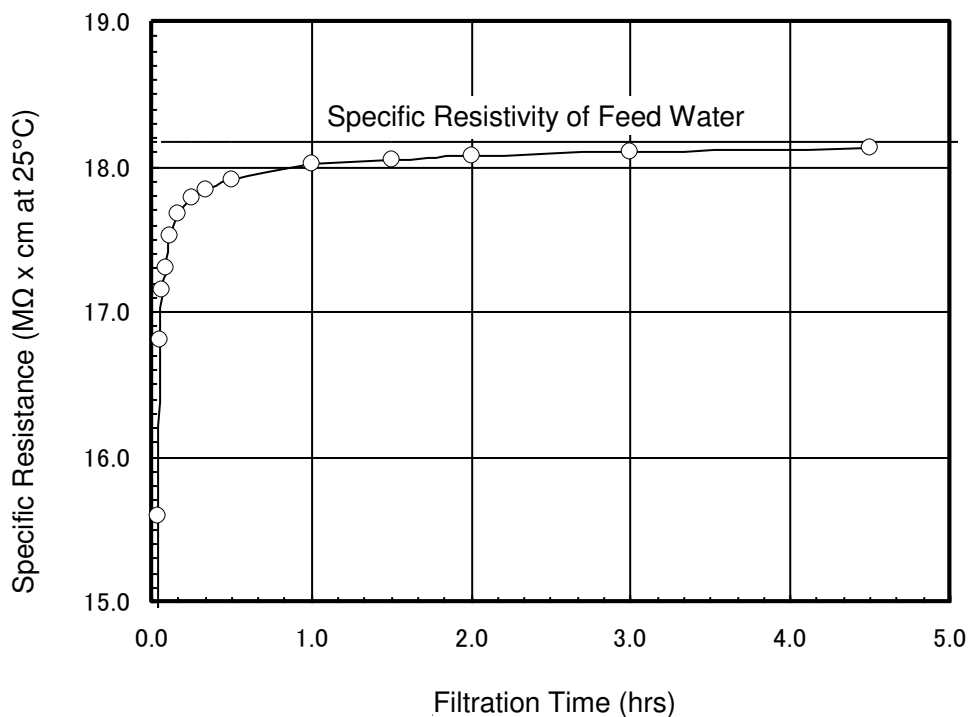

Test Condition

- ◆ Filtrate flow rate: 10.0 m³/hr per module
- ◆ Water recovery rate: 98%
- ◆ Specific resistivity of feed water: 18.17 MEG-cm (25°C)
- ◆ Conductivity meter: TOA-DKK-made AQ-11

Fig. 6-3-1 Data on Recoverability of Permeate Nonconductivity after Startup

Particle Data

Figure 6-3-2 shows data on particle removal.

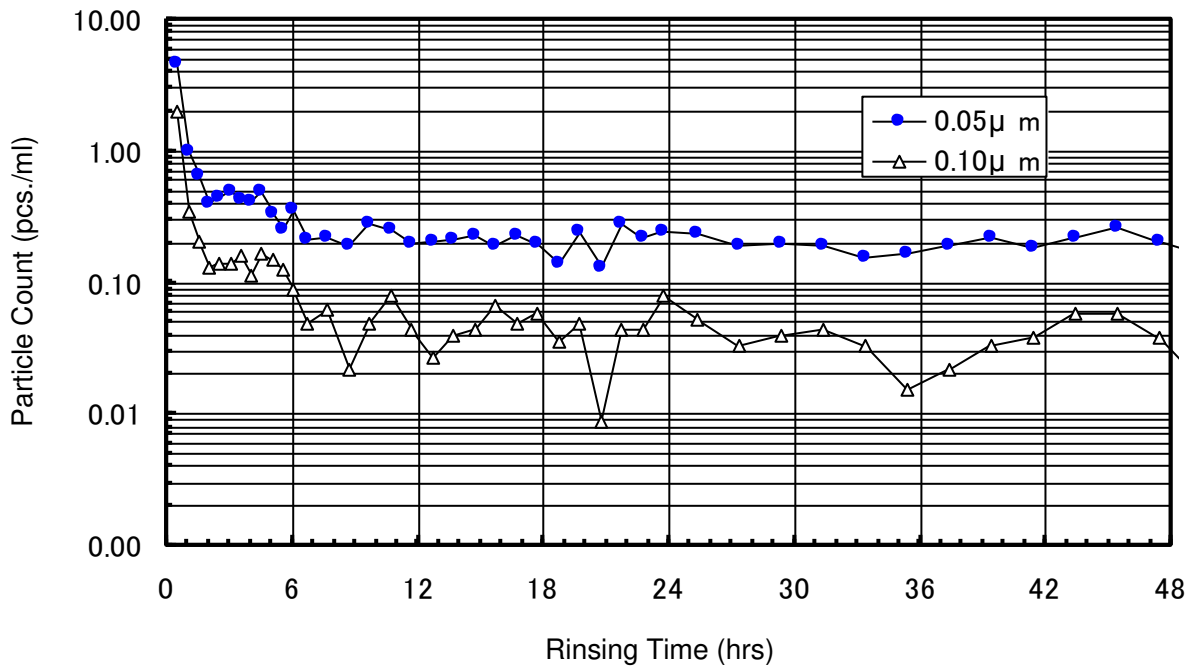

Test Condition

- ◆ Filtrate flow rate: 10 m³/hr per module (25±1°C)
- ◆ Particle counter: PMS-made Ultra DI-50

Figure 6-3-2 UF permeate particle counts exhibited after system startup

TOC Data

Figure 6-3-3 shows TOC exhibited during the early stages of rinse process.

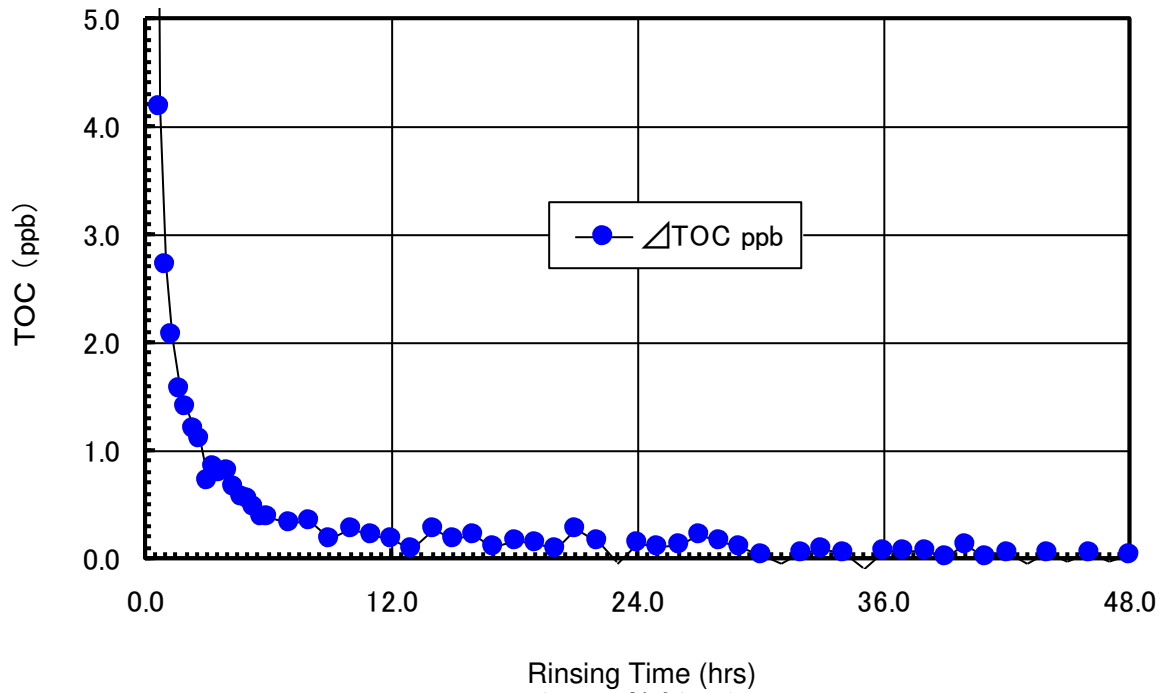

Test Condition

- ◆ Filtrate flow rate: 10 m³/hr per module (28 - 30°C)
- ◆ Water recovery rate: 98%
- ◆ Feed water quality: 1-2ppb of TOC
- ◆ TOC meter: Anatel-made A-1000

Figure 6-3-3 UF permeate TOC exhibited after system startup

7. HOW TO FIX MODULE & PIPING

7-1. How to Fix Module on a Rack

- ◆ The weight of a module is about 35kg, when filled with water fully. Module support, only by piping, is overload for module case and pipes. Adoption of special support is recommendable. References are given in Figure 7-1 and 7-2.
- ◆ Avoid fixing the module housing too tightly with U-bolts or suchlike as it may strain module pipe sections. The fixing should be light enough to prevent horizontal swings.
- ◆ The module should be placed in an upright position on the rack with the feed side at the bottom and concentrate side at the top. Feed nozzle and concentrate nozzle are designated clearly by labels on the module. No reverse is allowed.
- ◆ A stand should support the bottom cap nut of the module as shown in Figure 7-1. Fixing apparatus to keep module free from toppling is such as a band holding module loosely and lightly. Dimensions in the Figure 7-1 are standard ones.
- ◆ Connection pipes to module are of elbow type as shown in Figure 7-1. This piping method allows all module connection parts to be free from stress concentration. No supports be used for elbows but headers.
- ◆ Connection part of the filtrate nozzle of the module is union socket of 2.5S size. Use custom made sanitary clamp for the connection. The screwing torque of the clamp should be kept within 1.5 - 2.5N-m. It is recommended to be skilled to the torque by training with a torque wrench.
- ◆ Pipe elongates and shrinks thermally. Allowance for the expansion should be taken into consideration at module rack designing and piping.



Caution



Due to the high weight of the module, take a lower back problem preventive measure such as handling by two or more workers.



Caution



Fix the module with a U-band or chain to the module rack when installing modules. If the module falls down, it can cause injuries or damages to the module housing.



Caution



Do not over tighten such U-band clamps or chains. Do not tighten U-band clamps with a tool but with hands. When chains are used, ensure that they are slack. Over tightening a U-band clamp or a chain may damage the module housing.
If the module contacts an angle such as that of a metal part when secured, protect the module with cushioning.

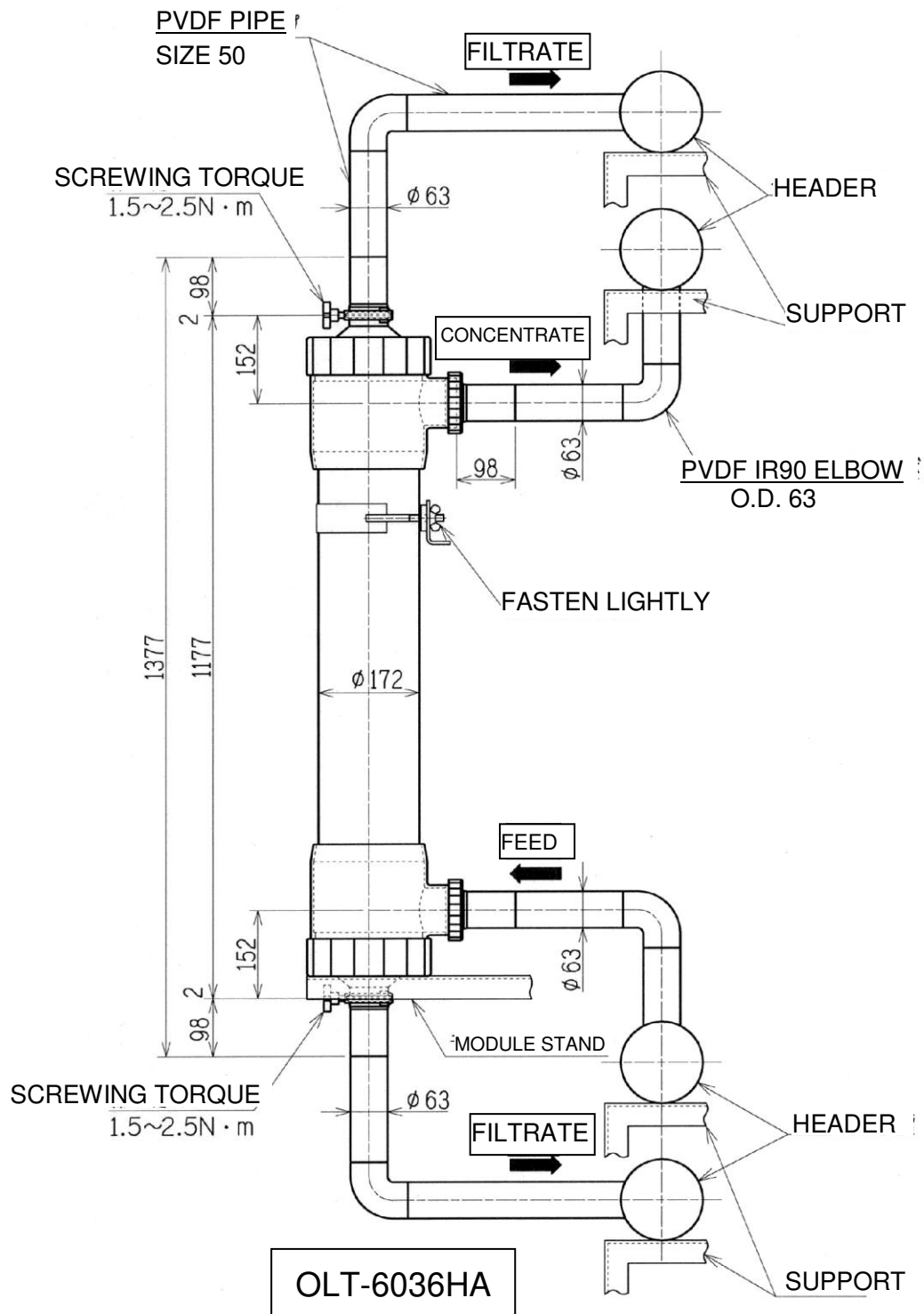

Fig. 7-1 Module Supporting Method

7-2. Example of Module Stand

Figure 7-2 shows an example of module stand. The figure and dimensions are only for reference. Use dummy module to fabricate and construct the stand. Note that the diameter of a dummy module (165mm ϕ) is different from that of the actual module (172mm ϕ).

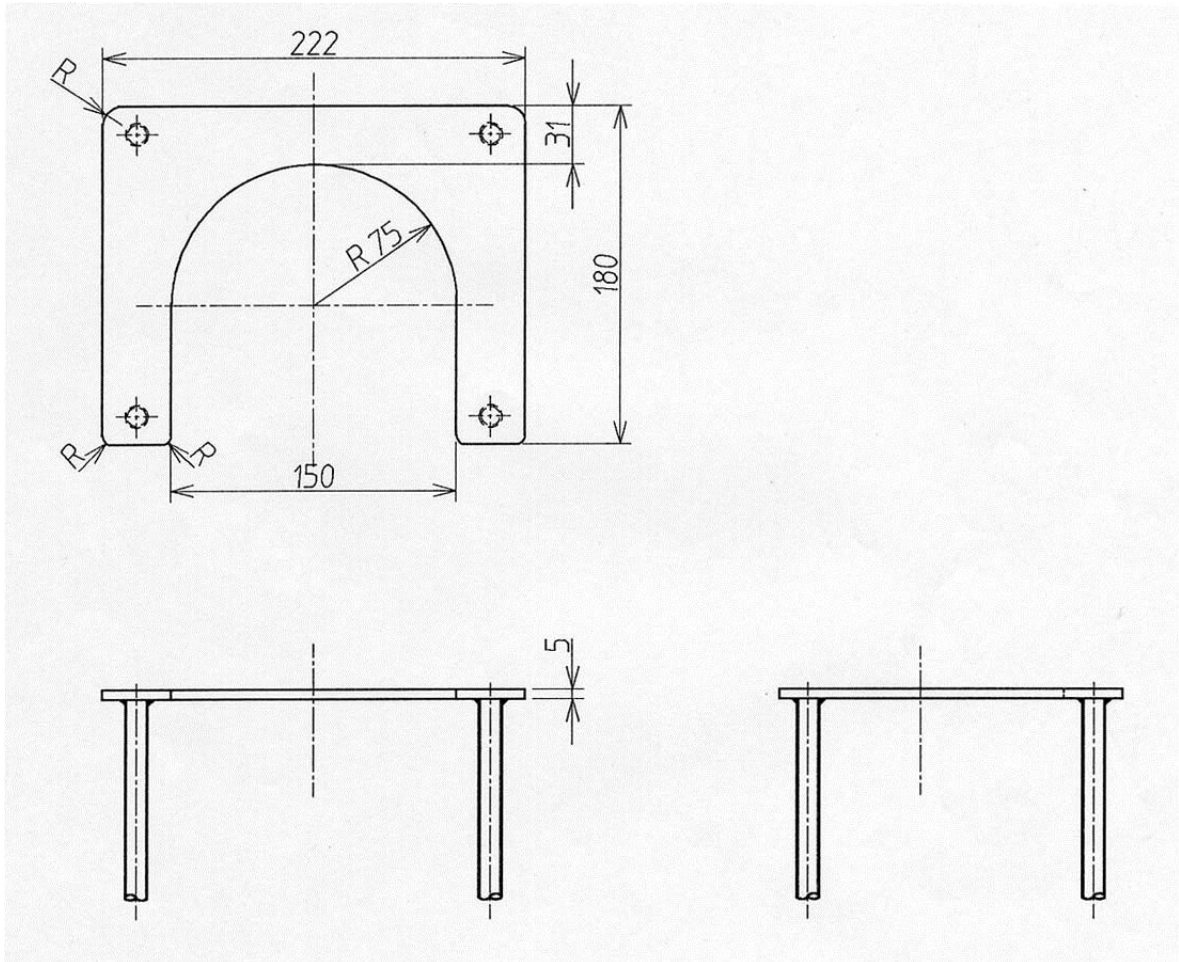

Fig. 7-2 Module Stand (Example)

7-3. Piping Design of Module Rack

The module has two filtrate nozzles at both ends of it. For piping installation, refer to the piping design examples below. For Example 2, it is recommendable to put filtrate headers higher than modules to avoid air bubbles remaining in the filtrate pipeline.

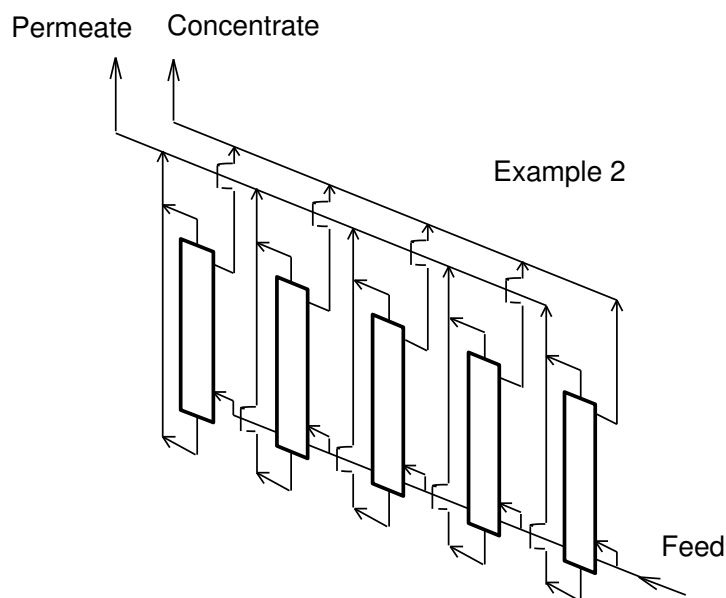
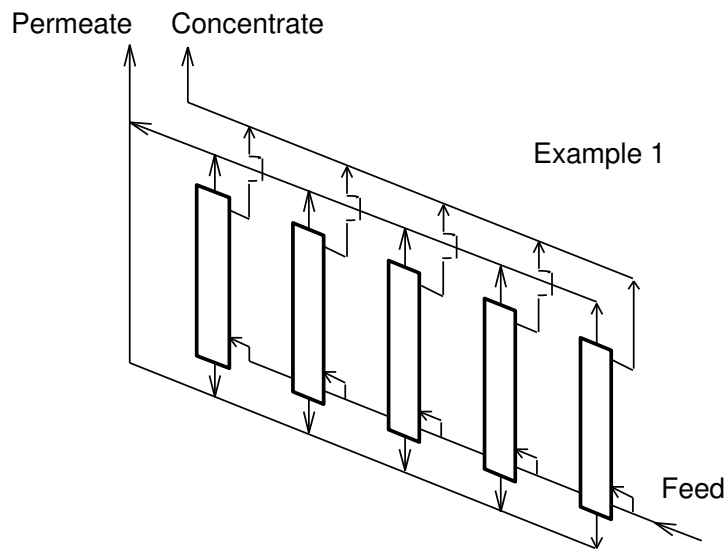
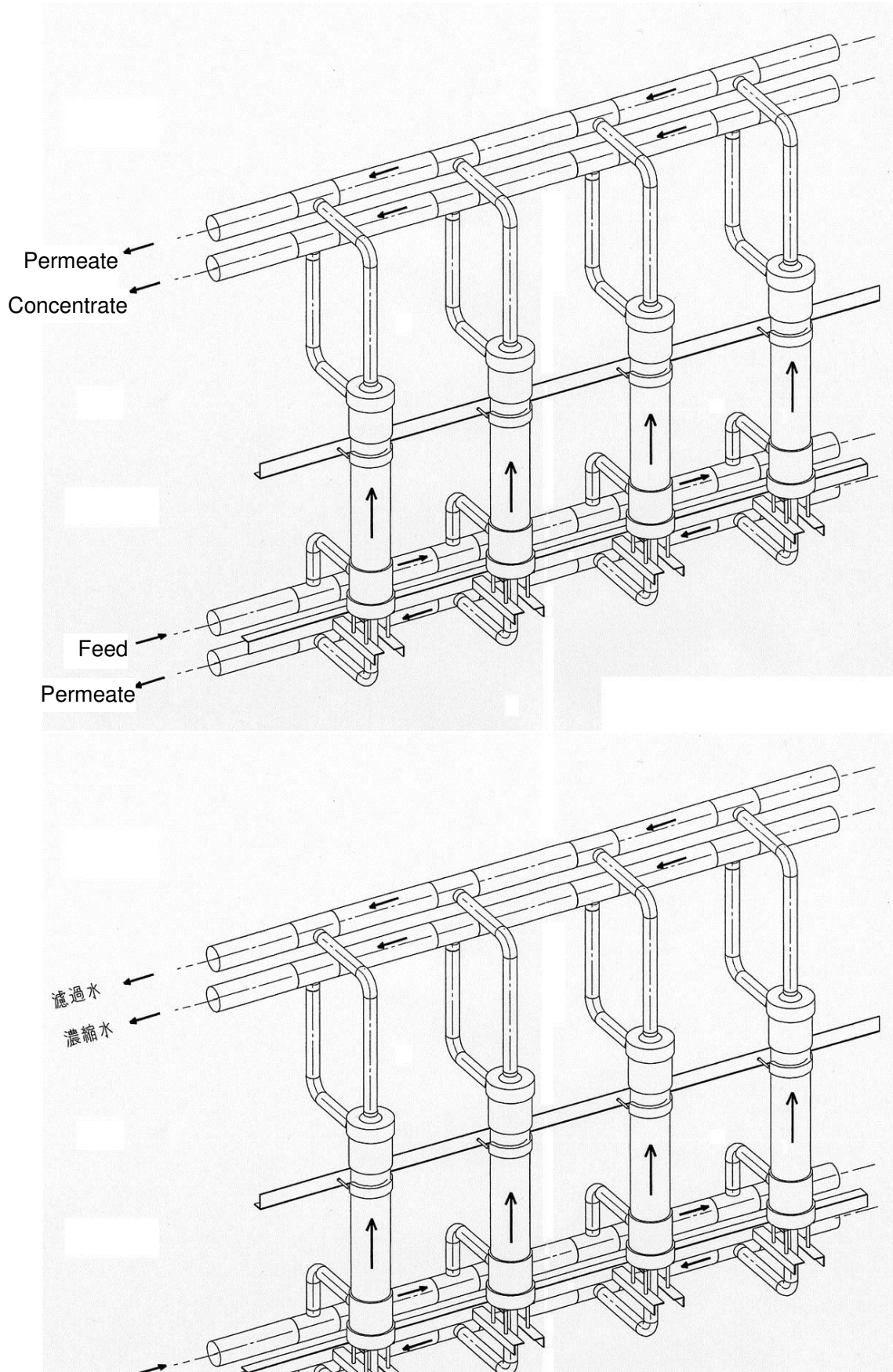

Fig.7-3 Piping Design of Rack

7-4. Example of Module Rack Structure

A perspective drawing of module rack is shown below as an example.



8. STANDARD OPERATING PARAMETERS

8-1. Recommended Operating Parameters

Recommendable operating parameters are given in the next table.

Table 8-1 Recommended Operating Parameters

Filtration mode	Outside-in constant flow filtration ^{*1}
Recovery rate of filtrate	90 - 99%
Filtration Pressure	Around 100 kPa and up gradually
Feed water quality requirement	(1) Particle count: <100pcs./ml, >0.1µm ditto: < 20pcs./ml, >0.2µm (2) Viable cell: <0.1cfu/ml (3) No membrane-clogging elution from IE resin, tank material, pipe material, etc.
Hot water sterilization requirement	(1) About one hour at a temperature of 90°C (2) Concentrate flow rate: Max. 300L/hr/module or less (3) Filtrate flow rate: 10 m ³ /hr or less per module
Concentrate conditions	Concentrate flow rate: Max. 1.0m ³ /hr/module or less

*1: Outside-in constant flow filtration is the standard filtration mode. Note that operation with a large flux change may degrade the performance of UF membrane or damage it.

8-2. Feed Water Quality Requirements

Feed water that contains large amount of particles and/or microorganisms cause decrease of membrane performance. Generally, water prepared by processes as shown below is recommendable as feed water. Location of raw water intake or raw water quality may also affect the performance of UF.

<Process flow diagrams of ultrapure water makeup plant>

Raw water ⇒ Pretreatment ⇒ Primary DI system ⇒ Sub-system

(Examples) (Example)

1) 2B3T +RO+MB+VDG UV_{ox}+AP+CP+UV+UF



2) RO+2B3T+MB+VDG+RO

3) RO+RO+ VDG+MBP

4) RO+EDI+CP

8-3. Recommendable Ultrapure Water Makeup Processes

- ◆ As mentioned in the previous paragraph, it is recommendable to use RO unit in the primary DI system to stabilize and improve water quality.
- ◆ To reuse concentrate water of UF unit, the concentrate should be returned to feed side of the previous RO unit. It is recommended that the particle count of the feed water be less than 100pcs./ml ($>0.1\mu\text{m}$) and the viable cell count be less than 0.1cfu/ml as standards. Even if these values are adhered to, other factors may degrade the filtration performance.
- ◆ Degasification unit in the primary makeup process prevents the adsorption of gas onto UF membrane, decrease of filtration performance, and accelerated deterioration of membrane. Adoption of a degasification unit (such as VDG) is recommendable.
- ◆ Eluted substances from ion exchange resin may affect the filtration performance of UF membrane. The following notices should be taken into consideration.
 1. Select the lowest elution resin available.
 2. Rinse the resin thoroughly before use.
 3. Remove free chlorine in feed to the resin unit. Free chlorine decomposes resins and resulting eluted substances blocks UF membrane.
- ◆ Pay attention to elution from tank and piping materials. Eluted substances may clog UF membrane. Periodical cleaning of machines and equipments that locate at previous stages of the water purification line is recommendable.
- ◆ Periodical hot water sanitization is recommended. Hot water sanitization also cleans the UF membrane and is very effective in preventing the degradation of the membrane performance. Refer to the section "Hot Water Sanitization" described below.

 Warning	
	Don't touch the hot parts of the UF unit, which could result in burns.

Note: Those recommendations above are not guarantees or conditions of guarantees.

Note: Designers and/or water engineering companies of UF units are requested to carefully read and follow this manual prior to designing and engineering.



9. INSTRUCTIONS FOR MODULE USE

9-1. Rinsing Method

Mount dummy modules to the UF unit and rinse thoroughly the whole stages of the water makeup line, including previous stages and the UF unit, before mounting the real UF modules. The pressure resistance of dummy module is max. 200 kPa.

The module contains 0.37% formaldehyde solution as preservative solution. Supply ultrapure water (>18 MEG-cm at 25°C) and rinse the UF unit until filtrate quality reaches a desired level. Don't soil the filtrate side (clean side) of the module during mounting work. Figure 6-3-1 shows an example of changes in the recoverability of permeate nonconductivity.

Some modules shipped overseas are filled with an aqueous preservative solution of 65% glycerine and 2% ethanol. Consult Asahi Kasei for data on rinsing these modules.

 Caution	
	The module may contain formaldehyde 0.37% preservative solution. Ventilate the environment for draining out and wear protectors to prevent the solution from touching eyes and hands.

9-2. Filtration Mode

The filtration mode of OLT-6036HA module is "Outside-In Constant Flow Filtration"

9-3. Average Filtration Pressure

Average filtration pressure (Ave. P) is defined by the formula.

$$\text{Ave. P} = \frac{(P_i + P_o)}{2} - \frac{P_{f1} + P_{f2}}{2}$$

- ◆ Max. feed pressure (P_i) is 1200 kPa (25°C).
- ◆ Max. transmembrane pressure is 300 kPa (25°C)
 - * Maximum transmembrane pressure is defined as " $P_i - P_{f1}$ "
- ◆ Decide design capacity of module considering feed water quality and other restrictive conditions.

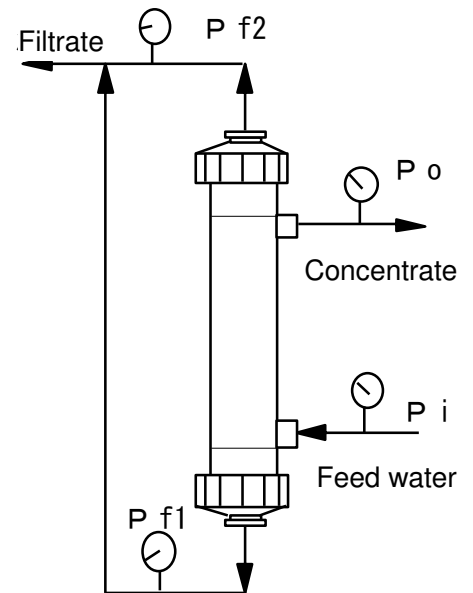

9-4. Recovery Rate

90 - 99% of feed volume is recovered as UF filtrate, generally. Remaining 1 - 10% is discharged from the UF unit as UF concentrate.



Note on Dead-end Filtration

Dead-end filtration (100% recovery of feed water as product) may cause an air buildup in the upper part of the module. This could lead to membrane drying and prevent normal filtration performance. Dead-end filtration may also cause quick fouling of UF membrane by particulates and/or bacteria and the membrane may lose filtration ability. Pay attention to following items if recovery rate comes closer to 100%.

- ◆ To confirm and follow feed water quality periodically
- ◆ Rising operation of recovery rate should be very slow. Spend several months.

9-5. Maximum Service Temperature

The maximum service temperature of the module is 80°C. Use the module at temperatures below 80°C unless otherwise used for hot water sanitization, described below. Such operation may cause module damage.



 Warning	
	<p>Operate UF module within allowed specification. The operation may damage the module.</p>

9-6 Feed Water Temperatures and Allowable Operating Pressures

Feed water temperature and operating pressure should be applied as specified in the following table. Operation under a higher pressure than specified may cause module damage.

Table 9-6 Feed Water Temperatures and Allowable Operating Pressures

UF feed water temperature (°C)	Max. trans-membrane pressure (kPa)	Max. feed water-side pressure (kPa)	Max. permeate-side pressure (kPa)
- <30	300	900	900
30 - <50	300	600	600
50 - <70	200	500	500
70 - <80	150	400	400

 Warning	
	<p>There are possibilities of scalding by hot water. Cover all dangerous parts and/or wear protectors. Also take measures such as providing covers around modules and units to prevent accidents caused by hot pipes or hot water (40°C or more) from pipe connections.</p>

9-7. Hot Water Sanitization

Two examples of hot water sanitization are shown below.

Hot Water Sanitization Flow 1

A hot water tank is provided, and hot water is fed to the UF membrane unit from the hot water tank. Water from the use point is then returned to the hot water tank. (The dashed lines in the figure show hot water lines.)

- ◆ Temperature raising method 1
Raise the temperature of the UF unit to 90°C, taking at least 15 minutes. After hot water sanitization, also take at least 15 minutes to bring the temperature back to normal.
- ◆ Temperature raising method 2
If a facility restriction does not allow gradual raising of water temperature, raise it in two steps. When the temperature of hot tank water reaches 50 to 60°C, feed the hot water to the UF modules for 10 or more minutes to raise the module temperature to a constant temperature of 50 to 60°C. Keep feeding hot water to the modules to raise the temperature of the hot tank water to 90°C. Decrease the temperature also in two steps.

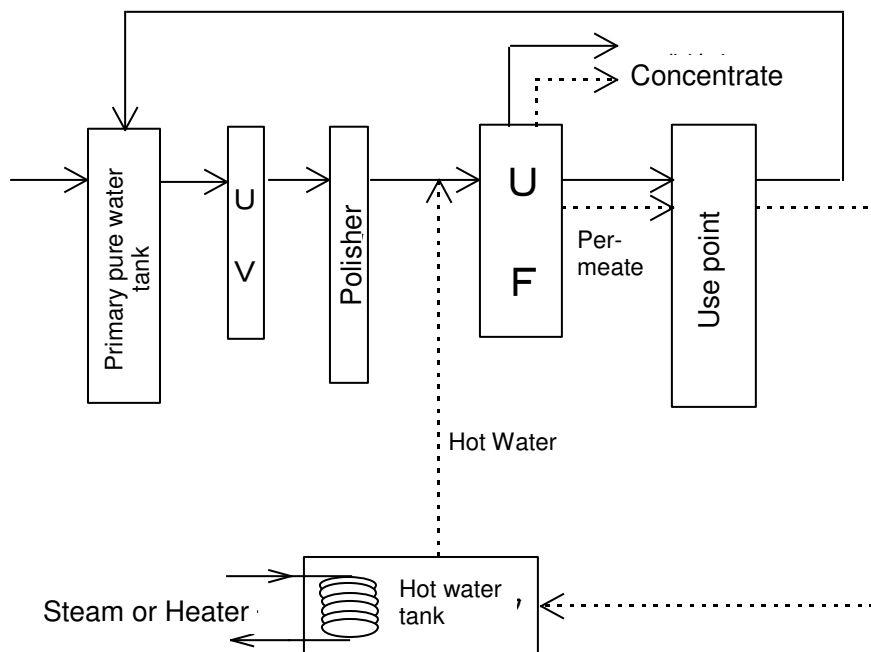

Fig. 9-7-1 Hot Water Sanitization Flow (1)

Hot Water Sanitization Flow 2

A heat exchanger is installed in the ultrapure water line before the UF modules and hot water is fed to the UF modules and use point. (The dashed lines in the figure show hot water lines.)

- ◆ Temperature raising method
Raise the temperature of the UF unit to 90°C, taking at least 15 minutes. After hot water sanitization, also take at least 15 minutes to bring the temperature back to normal.

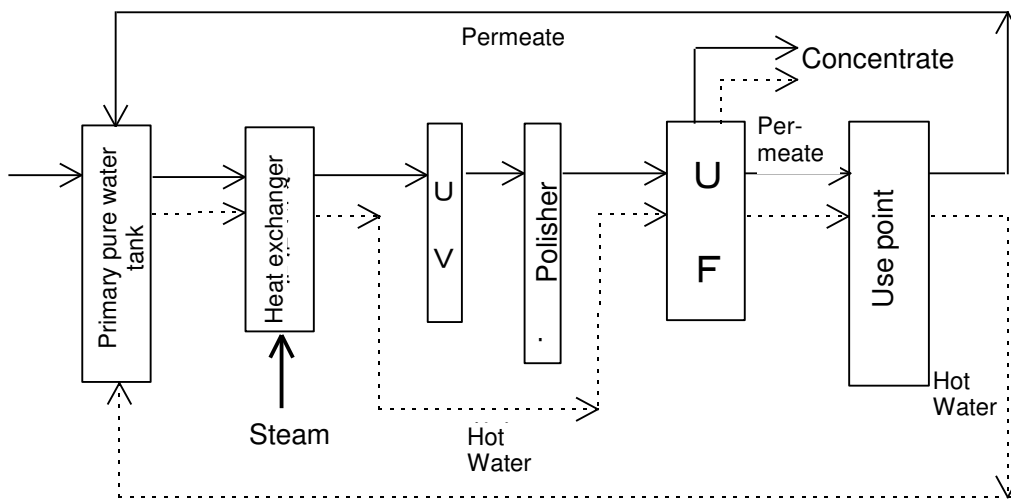

Fig. 9-7-2 Hot Water Sanitization Flow (2)

Notes on Hot DI Water Operation



Note the following for hot water sanitization:

- ◆ Feed water temperature and operating pressure in hot water sanitization should be applied as specified in the following table. Operation under a higher pressure than specified may cause module damage.

Table 9-7 Feed water temperatures and allowable operating pressures
in hot water sanitization

UF feed water temperature (°C)	Max. trans-membrane pressure (kPa)	Max. feed water-side pressure (kPa)	Max. permeate-side pressure (kPa)
- 90	100	500	500

- ◆ It is recommended that hot water of 90°C be run through the sections up to the end of the use point piping for one to two hours.
- ◆ If a cleaning effect on the UF module and piping is intended, about one-hour operation with hot water of 90°C is recommended. In this case, discharge 100 to 300 liters of concentrate an hour per module. (The concentrate in module must be discharged constantly from the concentrate-side port during hot water sanitization to prevent the buildup of air in the upper part of the module. Such air buildup could lead to membrane drying.)
- ◆ Take at least 15 minutes when raising the water temperature to 90°C to feed hot water to the UF modules. Also take 15 or more minutes when bringing the water temperature back to normal.
- ◆ Use of a sensor for high temperatures is recommended as hot water may pose a problem for a conductivity sensor.
- ◆ Automation of hot water sanitization is recommended, as the operation is likely to be performed frequently.
- ◆ Note that, if hot water is discharged from the UF unit right after hot water sanitization while the water is still hot, the UF membrane may dry quickly through contact with air and lose its performance as UF membrane.

 Warning	
	<p>There are possibilities of scalding by hot water. Cover all dangerous parts and/or wear protectors. Also take measures such as providing covers around modules and units to prevent accidents caused by hot pipes or hot water (40°C or more) from pipe connections.</p>

10. DRAWINGS OF MODULE AND PARTS

10-1. Module

Module in Shipping Package (Dwg. No.: AUM-OT60H-01)

Two sanitary gaskets for filtrate sanitary nozzles are packed in the container.

Module Connection Assembly (Dwg. No.: AUM-OT60H-02, AUM-OT60H-03)

Two filtrate nozzles are used as outlets of filtrate at all times.

10-2. Parts List (Standard Parts)

	Parts Name		Qty.	Materials	Parts No.
Standard Parts	Feed & Conc. side	Cap nut	2	GR-PPE	0450600
		O-ring: 63.8Φ x 3.5	2	F-rubber	0150611
		Blind plate: 85Φ	2	PP	0150618
	Filtrate side	3-piece clamp: 2.5S	2	SUS-304	0150613
		Sanitary gasket: 2.5S	2	F-rubber	0150612
		Blind plate: 77.5Φ	2	PP	0150617
PVDF Parts (Sold by request)	Feed & Conc. side	Union socket (feed & conc. side)	2	PVDF	0450602
		2-piece retainer ring	2	GR-PPE	0450600
		Cap nut	2	GR-PPE	0150611
		O-ring: 63.8Φ x 3.5	2	F-rubber	
	Filtrate side	Union socket (permeate side)	2	PVDF	0450603
		Sanitary gasket: 2.5S	2	F-rubber	0150612
C-PVC Parts for Normal Temperature (Sold by request)	Feed & Conc. side	Union socket (feed & conc. side)	2	C-PVC	0450604
		2-piece retainer ring	2	GR-PPE	0450600
		Cap nut	2	GR-PPE	0150611
		O-ring: 63.8Φ x 3.5	2	F-rubber	
	Filtrate side	Union socket (permeate side)	2	C-PVC	0450605
		Sanitary gasket: 2.5S	2	F-rubber	0150612
		3-piece clamp: 2.5S	2	SUS-304	0150613
	Dummy module		-	ABS and others	0450609

*GR-PPE: Glass fiber-reinforced modified polyphenylene ether resin

*F-rubber: Fluorocarbon rubber

Contact Asahi Kasei:

- ◆ If the specified filtration rate is not achieved
- ◆ A change of the originally intended application
- ◆ For module storage requirements exceeding one (1) year
- ◆ Requirement for more detailed information on UF system design
- ◆ Requirement for additional product parameters or information on product use

ASAHI KASEI CHEMICALS CORPORATION
MICROZA & WATER PROCESSING DIVISION

Jinbocho-Mitsui Building 1-105, Kanda Jinbocho, Chiyoda-ku, Tokyo
101-8101, Japan

Phone: +81-3-3296-3227

Fax: +81-3-3296-3449

Revised in April, 2012